

# Curotto Can Daily Preventive Maintenance Chart

Technicians Name: \_\_\_\_\_ Time Standard (hours): \_\_\_\_\_

RO Number: \_\_\_\_\_ Week of: \_\_\_\_\_ MFG: \_\_\_\_\_

Unit Number: \_\_\_\_\_ Campaign Due: Yes  No

## DAILY INSPECTIONS AND CHECKS

### 1.0 Pre-Trip Visual Inspection

1.1 Overall structural integrity. No damage to container, arm or slide.

1.2 No oil leaks from hydraulic components.

1.3 Grabber belts are without tears and no extensive wear.

1.4 Safety pins are in place, without damage and working properly.

1.5 Safety chains are in place, without damage and working properly.

PASSED FAILED REPAIRED BY: (INITIALS)	MON	TUE	WED	THU	FRI
	<input type="checkbox"/> <input type="checkbox"/> <input type="checkbox"/>	<input type="checkbox"/> <input type="checkbox"/> <input type="checkbox"/>	<input type="checkbox"/> <input type="checkbox"/> <input type="checkbox"/>	<input type="checkbox"/> <input type="checkbox"/> <input type="checkbox"/>	<input type="checkbox"/> <input type="checkbox"/> <input type="checkbox"/>
<input type="checkbox"/> <input type="checkbox"/> <input type="checkbox"/>	<input type="checkbox"/> <input type="checkbox"/> <input type="checkbox"/>	<input type="checkbox"/> <input type="checkbox"/> <input type="checkbox"/>	<input type="checkbox"/> <input type="checkbox"/> <input type="checkbox"/>	<input type="checkbox"/> <input type="checkbox"/> <input type="checkbox"/>	<input type="checkbox"/> <input type="checkbox"/> <input type="checkbox"/>
<input type="checkbox"/> <input type="checkbox"/> <input type="checkbox"/>	<input type="checkbox"/> <input type="checkbox"/> <input type="checkbox"/>	<input type="checkbox"/> <input type="checkbox"/> <input type="checkbox"/>	<input type="checkbox"/> <input type="checkbox"/> <input type="checkbox"/>	<input type="checkbox"/> <input type="checkbox"/> <input type="checkbox"/>	<input type="checkbox"/> <input type="checkbox"/> <input type="checkbox"/>
<input type="checkbox"/> <input type="checkbox"/> <input type="checkbox"/>	<input type="checkbox"/> <input type="checkbox"/> <input type="checkbox"/>	<input type="checkbox"/> <input type="checkbox"/> <input type="checkbox"/>	<input type="checkbox"/> <input type="checkbox"/> <input type="checkbox"/>	<input type="checkbox"/> <input type="checkbox"/> <input type="checkbox"/>	<input type="checkbox"/> <input type="checkbox"/> <input type="checkbox"/>

### 2.0 Pre-Trip Auto-Retract Check

2.1 Start engine and wait until air pressure gauge reaches 90 psi. Extend all cylinders minimum of 2" - then raise truck arms slightly and all three cylinders should fully retract.

2.2 Again extend all cylinders minimum of 2" then extend forks on truck - all three cylinders should fully retract.

<input type="checkbox"/> <input type="checkbox"/> <input type="checkbox"/>	<input type="checkbox"/> <input type="checkbox"/> <input type="checkbox"/>	<input type="checkbox"/> <input type="checkbox"/> <input type="checkbox"/>	<input type="checkbox"/> <input type="checkbox"/> <input type="checkbox"/>	<input type="checkbox"/> <input type="checkbox"/> <input type="checkbox"/>
<input type="checkbox"/> <input type="checkbox"/> <input type="checkbox"/>	<input type="checkbox"/> <input type="checkbox"/> <input type="checkbox"/>	<input type="checkbox"/> <input type="checkbox"/> <input type="checkbox"/>	<input type="checkbox"/> <input type="checkbox"/> <input type="checkbox"/>	<input type="checkbox"/> <input type="checkbox"/> <input type="checkbox"/>

### 3.0 Pre-Trip Cylinder Cushion Check

3.1 With engine running and minimum 90 psi of air pressure, fully retract the slide. Then close the grabbers and extend the dump cylinder. Check for adequate cushion at the top and bottom of the dump stroke. There should be a smooth cushion of the stroke about 1"-2" before the end of the stroke. The piston should not slam into the barrel end of the cylinder. CAUTION: Structural damage will occur if the cylinder cushions are not working properly.

<input type="checkbox"/> <input type="checkbox"/> <input type="checkbox"/>	<input type="checkbox"/> <input type="checkbox"/> <input type="checkbox"/>	<input type="checkbox"/> <input type="checkbox"/> <input type="checkbox"/>	<input type="checkbox"/> <input type="checkbox"/> <input type="checkbox"/>	<input type="checkbox"/> <input type="checkbox"/> <input type="checkbox"/>
--	--	--	--	--

### 4.0 Pre-Trip Gravity Hook Check

4.2 Make sure all three cylinders are fully retracted. Then shut off truck and REMOVE key. Check that the gravity hook is present by reaching around under the container. Then check that the gravity hook can rotate freely so that when the can is upside down the hook freely swings back and latches onto the anchor pin. WARNING: Unit cannot be operated until gravity hook is working properly.

<input type="checkbox"/> <input type="checkbox"/> <input type="checkbox"/>	<input type="checkbox"/> <input type="checkbox"/> <input type="checkbox"/>	<input type="checkbox"/> <input type="checkbox"/> <input type="checkbox"/>	<input type="checkbox"/> <input type="checkbox"/> <input type="checkbox"/>	<input type="checkbox"/> <input type="checkbox"/> <input type="checkbox"/>
--	--	--	--	--

### 5.0 Pre-Trip Packer Blade Lockout Check

5.1 With engine running and minimum 90 psi of air pressure - fully retract all three cylinders. Insure that all three cylinders are fully retracted. Then raise container slightly above the canopy. DO NOT put the container in the hopper. Press the Autopack button. Packer blade should not operate. WARNING: Unit cannot be operated until packer blade lockout is working properly.

<input type="checkbox"/> <input type="checkbox"/> <input type="checkbox"/>	<input type="checkbox"/> <input type="checkbox"/> <input type="checkbox"/>	<input type="checkbox"/> <input type="checkbox"/> <input type="checkbox"/>	<input type="checkbox"/> <input type="checkbox"/> <input type="checkbox"/>	<input type="checkbox"/> <input type="checkbox"/> <input type="checkbox"/>
--	--	--	--	--

# Curotto Can

## Weekly Preventive Maintenance Chart

### Weekly Inspection and System Checks

#### WEEKLY INSPECTIONS

##### 1.0 Structural on the Truck.

	PASSED	FAILED	REPAIRED BY: (INITIALS)	Second Week	Third Week	Fourth Week
1.1 Arm cylinder mounting brackets for cracks and mounting.	<input type="checkbox"/>	<input type="checkbox"/>	<input type="checkbox"/>	<input type="checkbox"/>	<input type="checkbox"/>	<input type="checkbox"/>
1.2 Upper and lower fork cylinder brackets for cracks and mounting.	<input type="checkbox"/>	<input type="checkbox"/>	<input type="checkbox"/>	<input type="checkbox"/>	<input type="checkbox"/>	<input type="checkbox"/>

Comments: \_\_\_\_\_

\_\_\_\_\_

##### 2.0 Structural on the Curotto Can.

2.1 Complete dump arm for cracks and damage.	<input type="checkbox"/>	<input type="checkbox"/>	<input type="checkbox"/>	<input type="checkbox"/>	<input type="checkbox"/>	<input type="checkbox"/>
2.2 Grabber assembly for cracks and hub caps are present on the spindles.	<input type="checkbox"/>	<input type="checkbox"/>	<input type="checkbox"/>	<input type="checkbox"/>	<input type="checkbox"/>	<input type="checkbox"/>
2.3 Carriage assembly, slide and brackets for cracks and damage.	<input type="checkbox"/>	<input type="checkbox"/>	<input type="checkbox"/>	<input type="checkbox"/>	<input type="checkbox"/>	<input type="checkbox"/>
2.4 Container pockets and corners for cracks and overall integrity.	<input type="checkbox"/>	<input type="checkbox"/>	<input type="checkbox"/>	<input type="checkbox"/>	<input type="checkbox"/>	<input type="checkbox"/>
2.5 All cylinder mounting brackets for cracks and overall integrity.	<input type="checkbox"/>	<input type="checkbox"/>	<input type="checkbox"/>	<input type="checkbox"/>	<input type="checkbox"/>	<input type="checkbox"/>

Comments: \_\_\_\_\_

\_\_\_\_\_

#### WEEKLY CHECKS

##### 3.0 Mechanical on the Truck.

3.1 Truck arm hydraulic lines are secure and without damage or wear.	<input type="checkbox"/>	<input type="checkbox"/>	<input type="checkbox"/>	<input type="checkbox"/>	<input type="checkbox"/>	<input type="checkbox"/>
3.2 Electrical and hydraulic lines are secure and routed properly around the fork pivot area.. NOTE: Critical Area - If lines are chafing or loose around the fork pivot - the problem needs to be repaired immediately.	<input type="checkbox"/>	<input type="checkbox"/>	<input type="checkbox"/>	<input type="checkbox"/>	<input type="checkbox"/>	<input type="checkbox"/>

##### 4.0 Mechanical on the Curotto Can

Electrical Components	PASSED	FAILED	REPAIRED BY: (INITIALS)	Second Week	Third Week	Fourth Week
4.1 Electrical wiring harness plug is secure and without damage.	<input type="checkbox"/>	<input type="checkbox"/>	<input type="checkbox"/>	<input type="checkbox"/>	<input type="checkbox"/>	<input type="checkbox"/>
4.2 Wiring harness from coupler to main valve is secure and intact.	<input type="checkbox"/>	<input type="checkbox"/>	<input type="checkbox"/>	<input type="checkbox"/>	<input type="checkbox"/>	<input type="checkbox"/>
4.3 Electrical solenoids on main valve are secure and without damage.	<input type="checkbox"/>	<input type="checkbox"/>	<input type="checkbox"/>	<input type="checkbox"/>	<input type="checkbox"/>	<input type="checkbox"/>
Hydraulic Components	PASSED	FAILED	REPAIRED BY: (INITIALS)	Second Week	Third Week	Fourth Week
4.4 Quick-disconnects are secured properly and without leaks or damage.	<input type="checkbox"/>	<input type="checkbox"/>	<input type="checkbox"/>	<input type="checkbox"/>	<input type="checkbox"/>	<input type="checkbox"/>
4.5 Hydraulic lines are secured and do not hang up when can is dumped.	<input type="checkbox"/>	<input type="checkbox"/>	<input type="checkbox"/>	<input type="checkbox"/>	<input type="checkbox"/>	<input type="checkbox"/>
4.6 Main hydraulic valve is secure and not leaking.	<input type="checkbox"/>	<input type="checkbox"/>	<input type="checkbox"/>	<input type="checkbox"/>	<input type="checkbox"/>	<input type="checkbox"/>
4.7 Hydraulic lines from main valve to cylinders are secure and not leaking.	<input type="checkbox"/>	<input type="checkbox"/>	<input type="checkbox"/>	<input type="checkbox"/>	<input type="checkbox"/>	<input type="checkbox"/>
4.8 All cylinders are undamaged and without leaks.	<input type="checkbox"/>	<input type="checkbox"/>	<input type="checkbox"/>	<input type="checkbox"/>	<input type="checkbox"/>	<input type="checkbox"/>

# Curotto Can

## Weekly Preventive Maintenance Chart

### Preventative Maintenance Chart

#### WEEKLY CHECKS

#### 4.0 Mechanical on the Curotto Can

Mechanical Assemblies	PASSED	FAILED	REPAIRED BY: (INITIALS)	Second Week			Third Week			Fourth Week		
				<input type="checkbox"/>	<input type="checkbox"/>	<input type="checkbox"/>	<input type="checkbox"/>	<input type="checkbox"/>	<input type="checkbox"/>	<input type="checkbox"/>	<input type="checkbox"/>	<input type="checkbox"/>
4.1 Top and bottom roller bearings on the slide for excessive wear.	<input type="checkbox"/>	<input type="checkbox"/>	<input type="checkbox"/>	<input type="checkbox"/>	<input type="checkbox"/>	<input type="checkbox"/>	<input type="checkbox"/>	<input type="checkbox"/>	<input type="checkbox"/>	<input type="checkbox"/>	<input type="checkbox"/>	<input type="checkbox"/>
4.2 Grabber bottom plate assembly bolts are secure.	<input type="checkbox"/>	<input type="checkbox"/>	<input type="checkbox"/>	<input type="checkbox"/>	<input type="checkbox"/>	<input type="checkbox"/>	<input type="checkbox"/>	<input type="checkbox"/>	<input type="checkbox"/>	<input type="checkbox"/>	<input type="checkbox"/>	<input type="checkbox"/>
4.3 Grabber shows no signs of rubbing on the container pocket or wall.	<input type="checkbox"/>	<input type="checkbox"/>	<input type="checkbox"/>	<input type="checkbox"/>	<input type="checkbox"/>	<input type="checkbox"/>	<input type="checkbox"/>	<input type="checkbox"/>	<input type="checkbox"/>	<input type="checkbox"/>	<input type="checkbox"/>	<input type="checkbox"/>
4.4 Dump Arm Pivot Pin: Lift up on the grabber assembly to see whether the total vertical movement exceeds one inch. If it does - replace the dump arm pivot pin and bushing.	<input type="checkbox"/>	<input type="checkbox"/>	<input type="checkbox"/>	<input type="checkbox"/>	<input type="checkbox"/>	<input type="checkbox"/>	<input type="checkbox"/>	<input type="checkbox"/>	<input type="checkbox"/>	<input type="checkbox"/>	<input type="checkbox"/>	<input type="checkbox"/>
4.3 Slide Assembly: Start engine, power up main pump and Curotto Can. Fully extend the carriage. Shut motor OFF. Remove key from the ignition. Check all four nylon wear strips on slide for extensive wear.	<input type="checkbox"/>	<input type="checkbox"/>	<input type="checkbox"/>	<input type="checkbox"/>	<input type="checkbox"/>	<input type="checkbox"/>	<input type="checkbox"/>	<input type="checkbox"/>	<input type="checkbox"/>	<input type="checkbox"/>	<input type="checkbox"/>	<input type="checkbox"/>

Comments: \_\_\_\_\_

#### 5.0 WEEKLY LUBRICATION

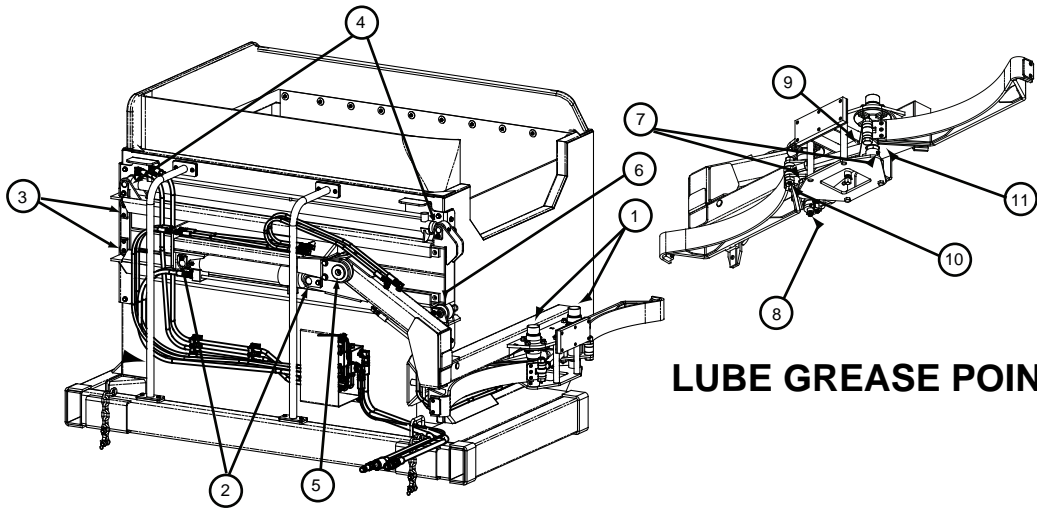

LUBE GREASE POINTS

1. Hub Assembly: 2 hubs forward and rear.	<input type="checkbox"/>	<input type="checkbox"/>	<input type="checkbox"/>	<input type="checkbox"/>
2. Dump Cylinder Pins: 2 points shaft and barrel end.	<input type="checkbox"/>	<input type="checkbox"/>	<input type="checkbox"/>	<input type="checkbox"/>
3. Slide Roller Bearings: 2 points upper and lower.	<input type="checkbox"/>	<input type="checkbox"/>	<input type="checkbox"/>	<input type="checkbox"/>
4. Slide Cylinder Pins: 2 points shaft and barrel end.	<input type="checkbox"/>	<input type="checkbox"/>	<input type="checkbox"/>	<input type="checkbox"/>
5. Dump Arm Pivot Pin: 1 point.	<input type="checkbox"/>	<input type="checkbox"/>	<input type="checkbox"/>	<input type="checkbox"/>
6. Cam Follower: 1 point	<input type="checkbox"/>	<input type="checkbox"/>	<input type="checkbox"/>	<input type="checkbox"/>
7. Hub Collars: 2 points	<input type="checkbox"/>	<input type="checkbox"/>	<input type="checkbox"/>	<input type="checkbox"/>
8. Grab cylinder Pin: 1 point	<input type="checkbox"/>	<input type="checkbox"/>	<input type="checkbox"/>	<input type="checkbox"/>
9. Grab Cylinder Pin: 1 point	<input type="checkbox"/>	<input type="checkbox"/>	<input type="checkbox"/>	<input type="checkbox"/>
10. Link Pin: 1 point	<input type="checkbox"/>	<input type="checkbox"/>	<input type="checkbox"/>	<input type="checkbox"/>
11. Link Pin: 1 point	<input type="checkbox"/>	<input type="checkbox"/>	<input type="checkbox"/>	<input type="checkbox"/>
12. Inspect hydraulic oil level in the tank.	<input type="checkbox"/>	<input type="checkbox"/>	<input type="checkbox"/>	<input type="checkbox"/>

Sign Off and Date \_\_\_\_\_

### Monthly Inspection and System Checks In Addition to the Weekly Checks

#### **MONTHLY CHECKS**

##### 6.0 Hydraulic and Cycle Time Checks

6.1 Check function of upper and lower decel valve on the arms of the truck.

6.2 Check cycle times.

Full slide extend not faster than:	2.5 seconds
Full slide retract not faster than:	1.5 seconds
Dump cycle not faster than:	2.0 seconds
Dump return not faster than:	1.2 seconds
Grab close not faster than:	1.0 seconds
Grab open not faster than:	1.0 seconds

PASSED   
FAILED   
REPAIRED   
BY: (INITIALS)

Comments: \_\_\_\_\_  
\_\_\_\_\_  
\_\_\_\_\_

\_\_\_\_\_  
Sign Off and Date

#### **SIX MONTH CHECK**

### Six Month Inspection and System Checks In Addition to the Weekly and Monthly Checks

##### 7.0 Hydraulic flow

7.1 Check hydraulic flow to the can.

Flow going to the P port on the can valve body should not exceed 12 gpm at 2000 psi.

Comments: \_\_\_\_\_  
\_\_\_\_\_  
\_\_\_\_\_  
\_\_\_\_\_  
\_\_\_\_\_  
\_\_\_\_\_  
\_\_\_\_\_  
\_\_\_\_\_  
\_\_\_\_\_

\_\_\_\_\_  
Sign Off and Date